

Gdp, Solución Informática a la Gestión de la Producción en Madera y Mueble

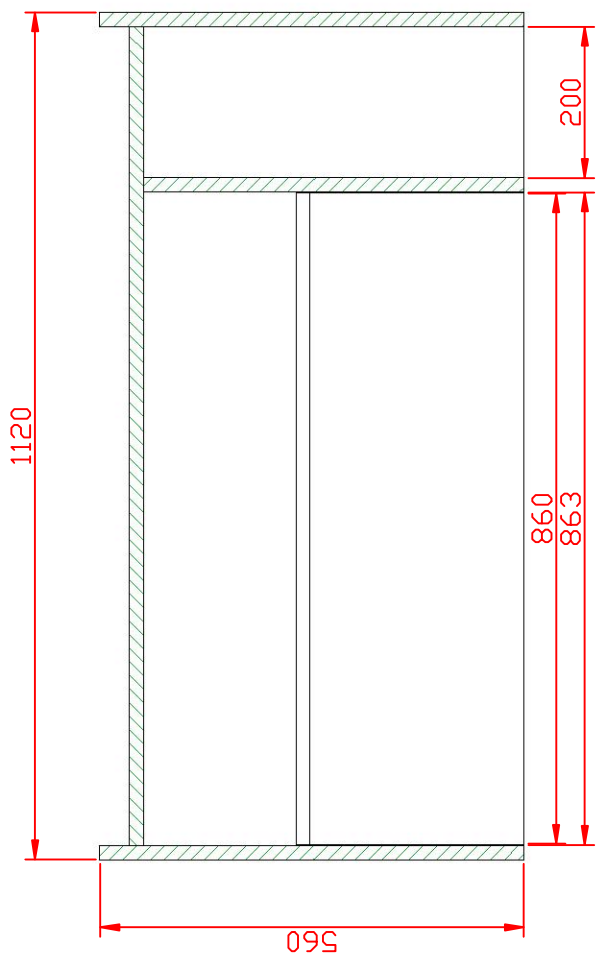

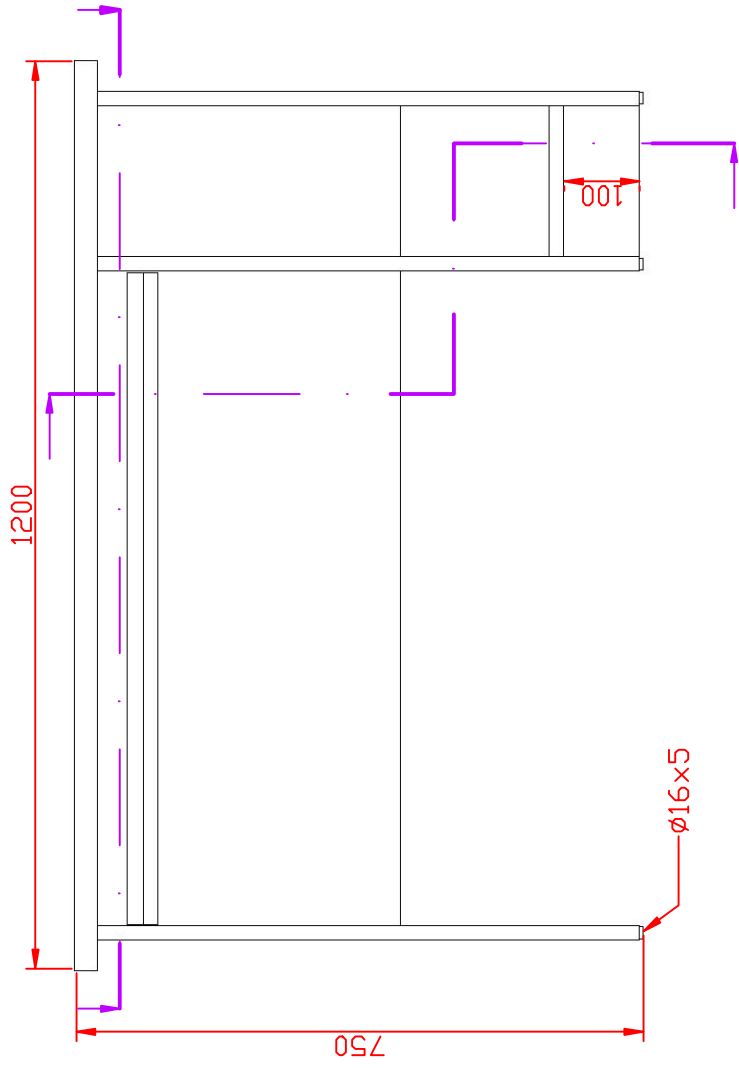

Alumno Pmm1 2012/05/16		 C.I.F.P. Pico Frentes SORIA		1
MESA		PMMI		1
1:10		MESA OFICINA GDP		1

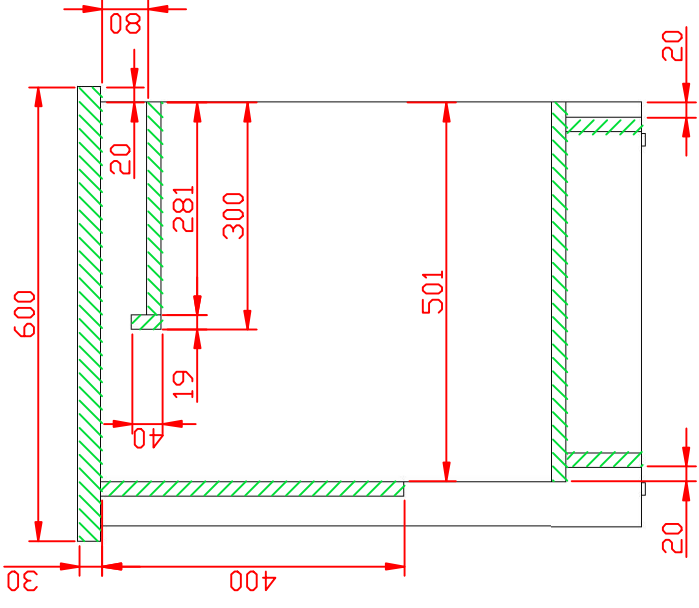
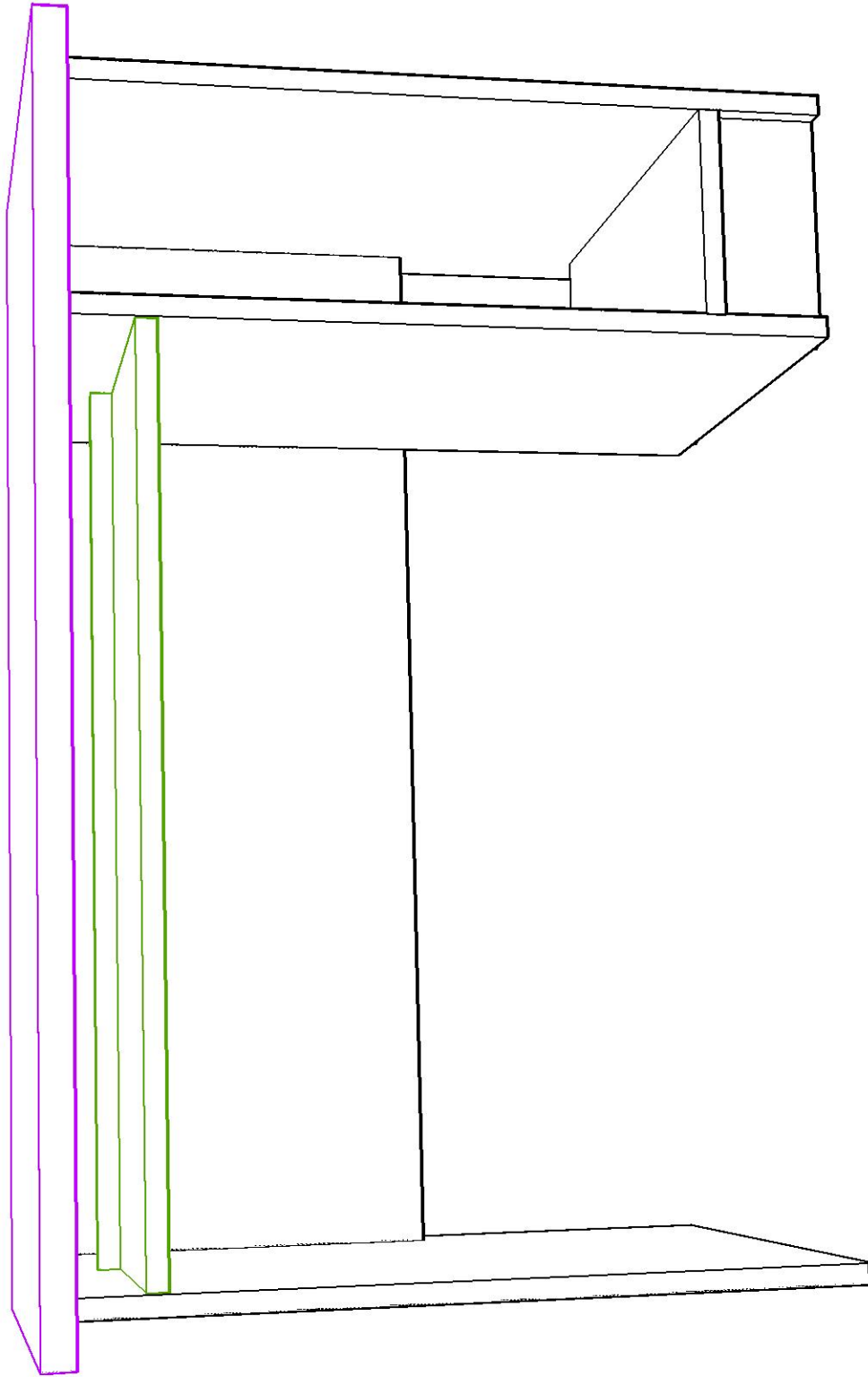

Alumno Pmm1		C.I.F.P. Pico Frenles
2012/05/10		SORIA
MESA	1:10	MESA OFICINA GDP
		2

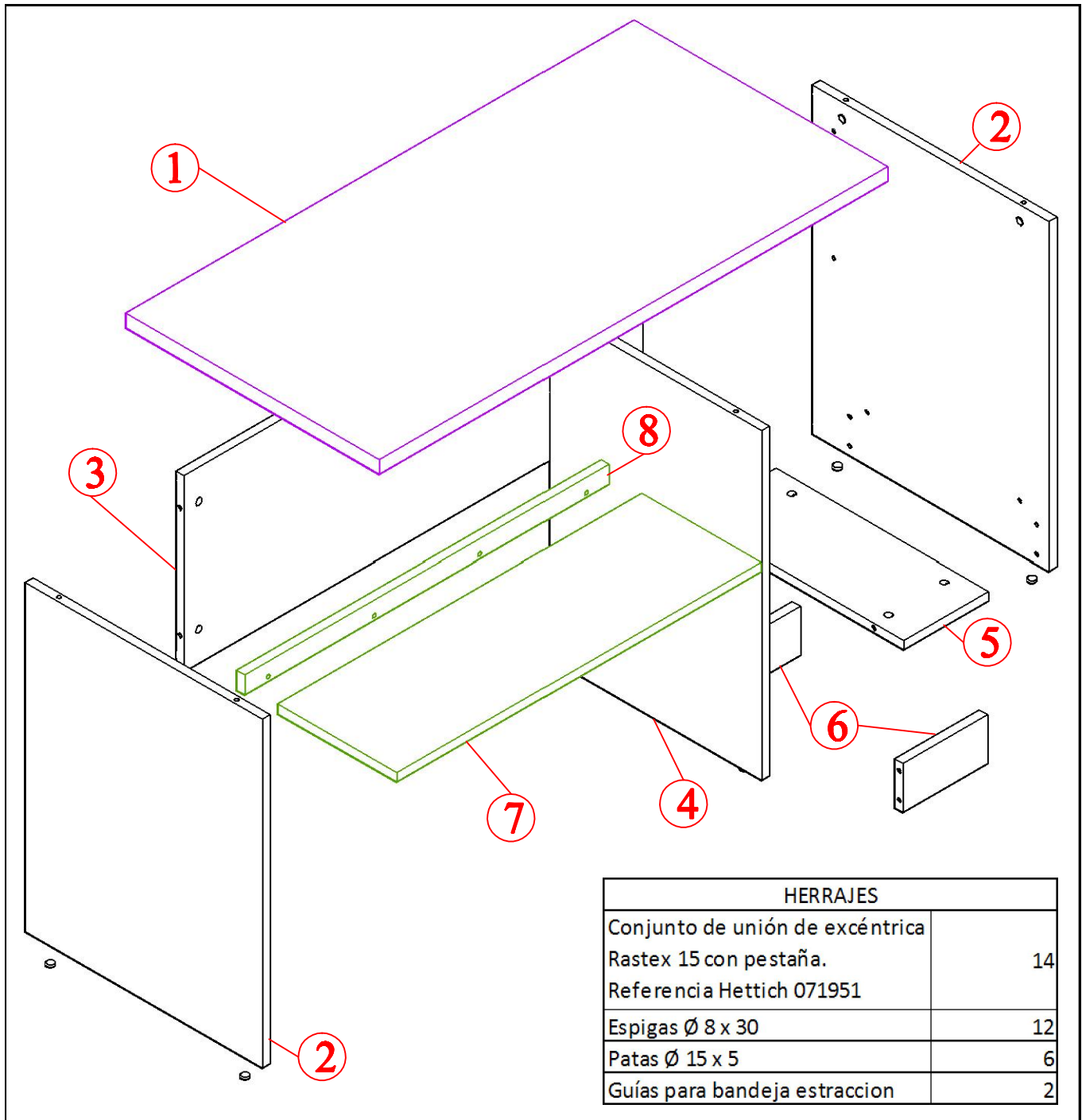

8	RESGUARDO	1	860	4	19	Tablero melamina
7	BANDEJA	1	860	281	19	Tablero melamina
6	ZOCALOS	2	200	100	19	Tablero melamina
5	BALDA	1	200	501	19	Tablero melamina
4	SEPARADOR	1	715	501	19	Tablero melamina
3	TRASERA	1	1082	400	19	Tablero melamina
2	LATERALES	2	715	560	19	Tablero melamina
1	TAPA	1	1200	600	30	Tablero melamina
REFERENCIA	DESCRIPCION	UNIDADES	LARGO	ANCHO	ESPESOR	MATERIAL

Alumno Pmm1		 PMM1		C.I.F.P. Pico Frentes SORIA		
2012/05/16						
ESCALA	LISTA DESPIECE					LAMINA
1:10						3

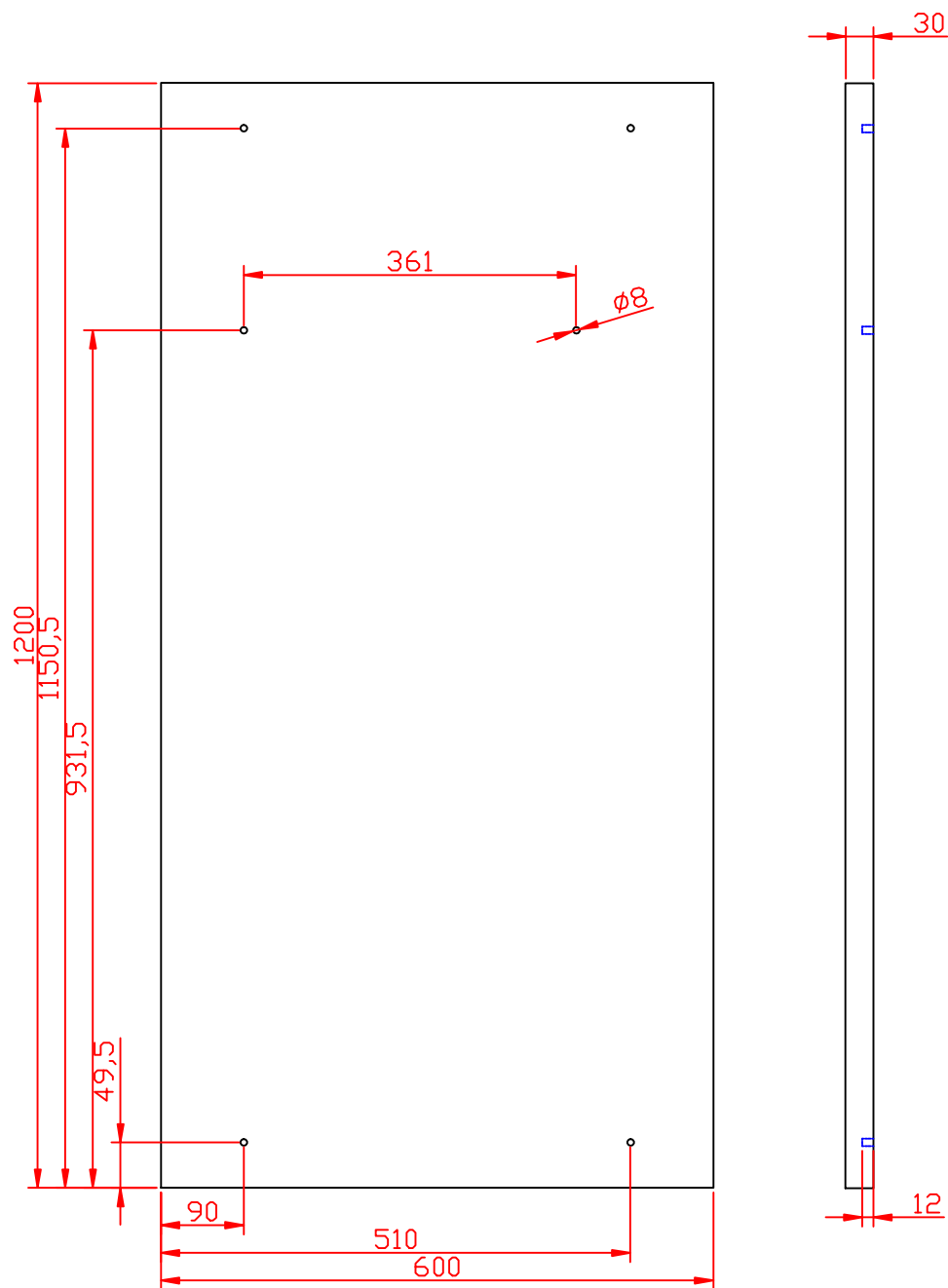

Alumno Pmm1

2012/05/17



PMM1



**C.I.F.P. Pico Frentes
SORIA**

ESCALA

1:8

DESPIECE -TAPA

LAMINA

4.1

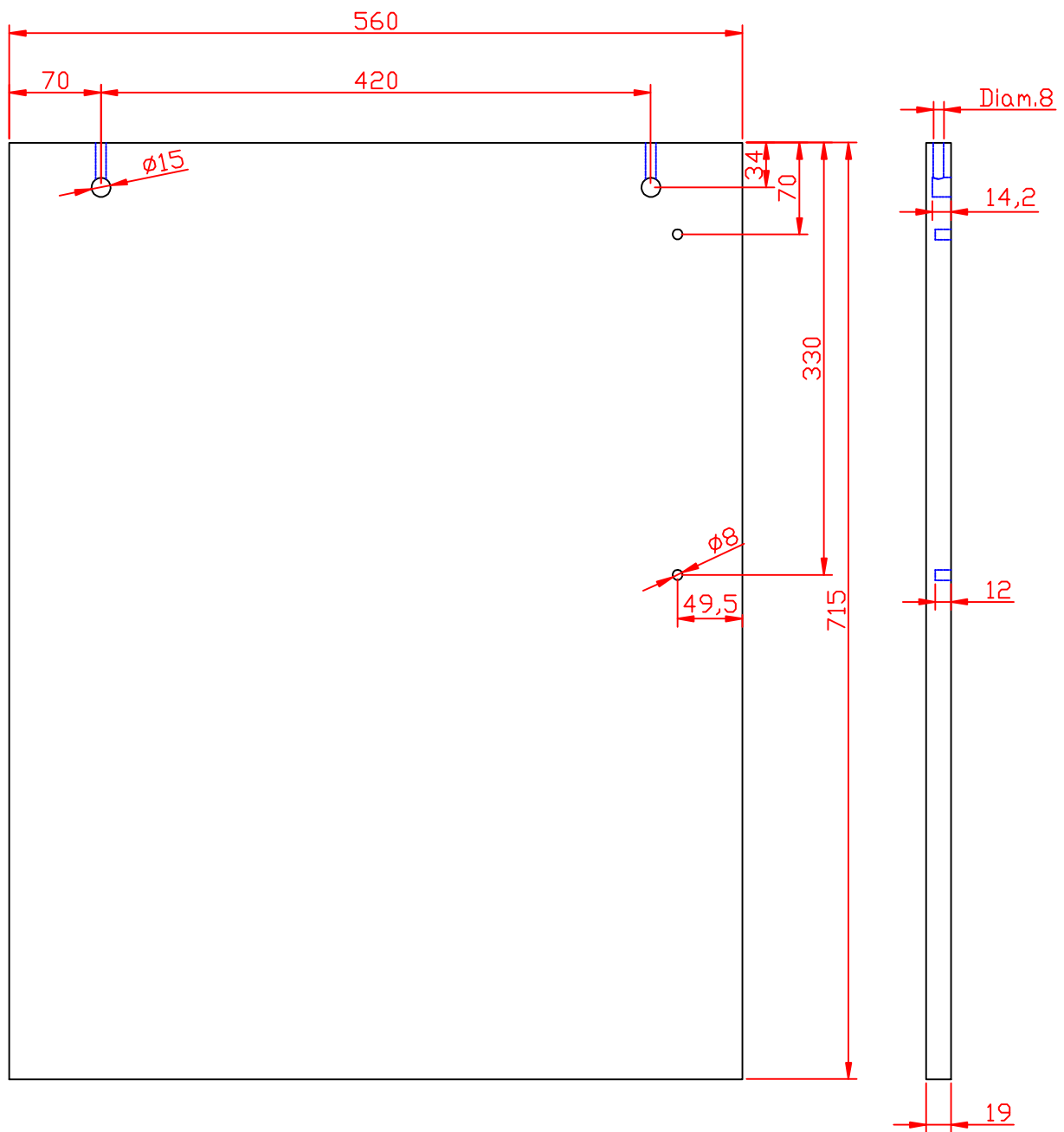

Alumno Pmm1



C.I.F.P. Pico Frentes
SORIA

2012/05/15

PMM1

ESCALA

1:5

DESPIECE-LATERAL IZDO

LAMINA

4.2.1

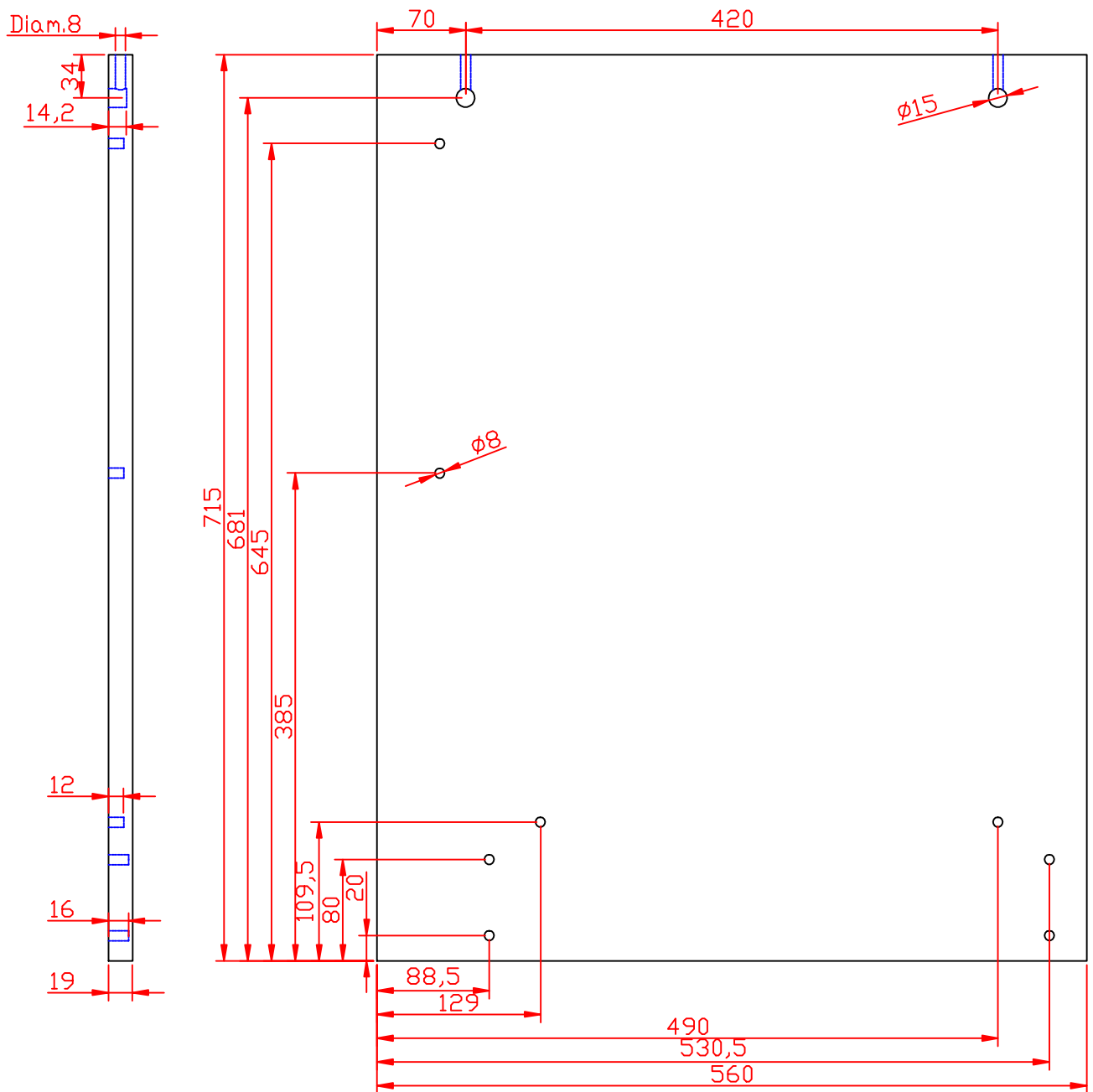

Alumno Pmm1



C.I.F.P. Pico Frentes
SORIA

2012/05/15

PMM1

ESCALA

LAMINA

1:5

DESPIECE-LATERAL DCHO

4.2.2

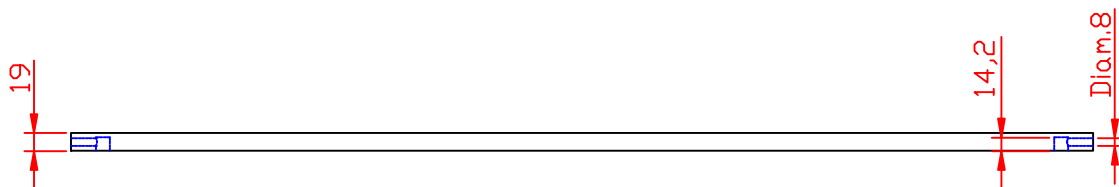
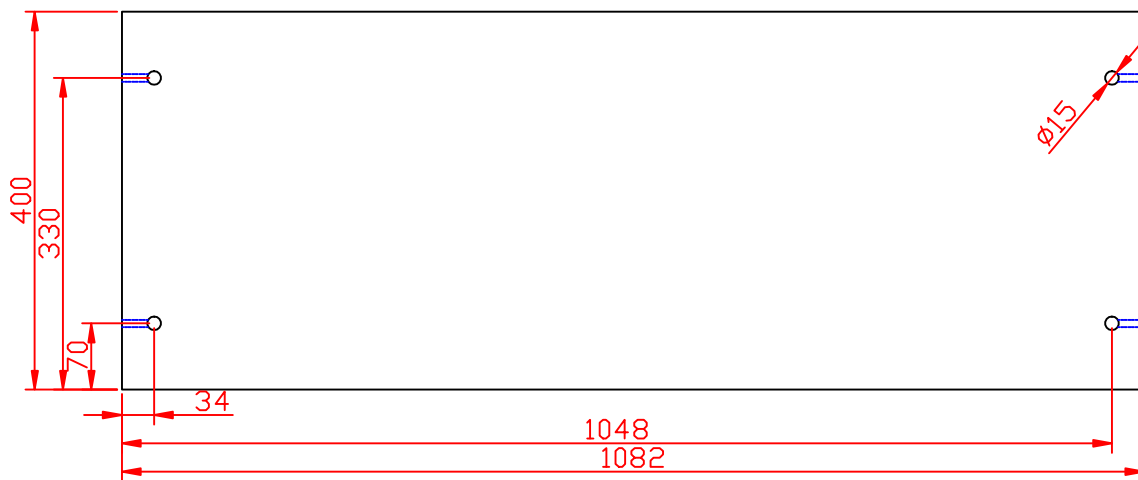

Alumno Pmm1

2012/05/15



PMM1



C.I.F.P. Pico Frentes
SORIA

ESCALA

1:8

DESPIECE-TRASERA

LAMINA

4.3

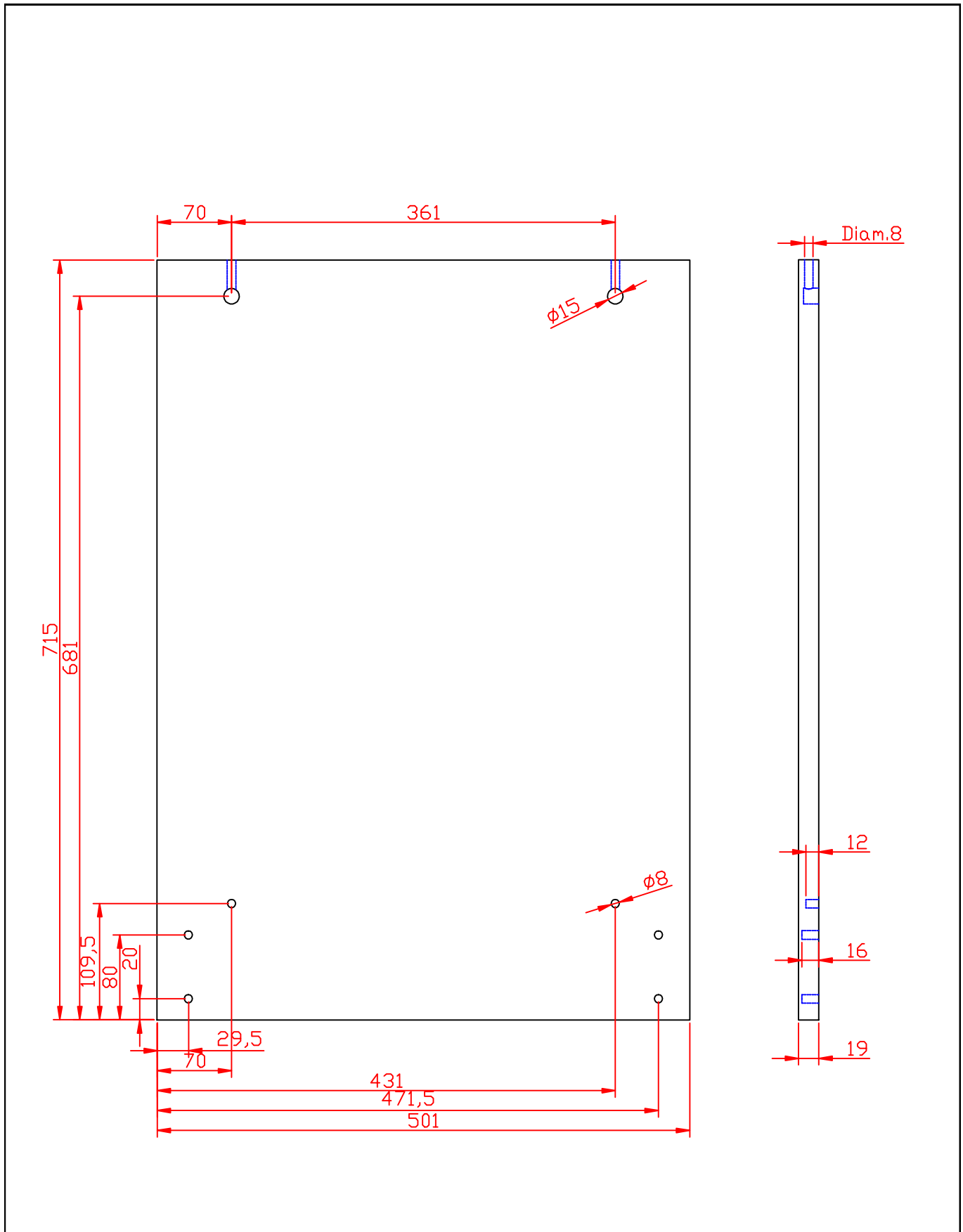

Alumno Pmm1		C.I.F.P. Pico Frentes	
2012/05/16	PMM1	 SORIA	
ESCALA			LAMINA
1:5	DESPIECE -SEPARADOR		4.4

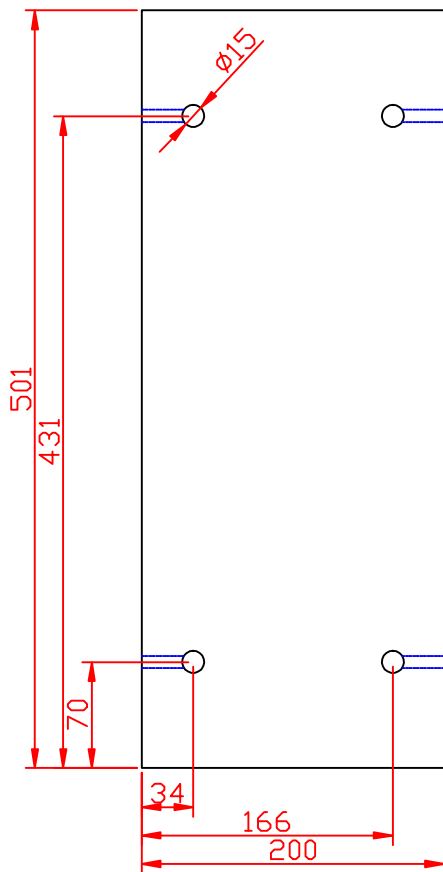
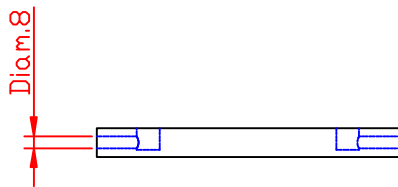

Alumno Pmm1



C.I.F.P. Pico Frentes
SORIA

2012/05/17

PMM1

ESCALA

LAMINA

1:5

DESPIECE -BALDA

4.5

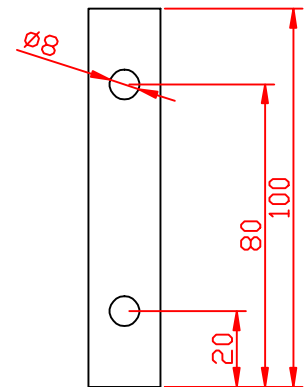
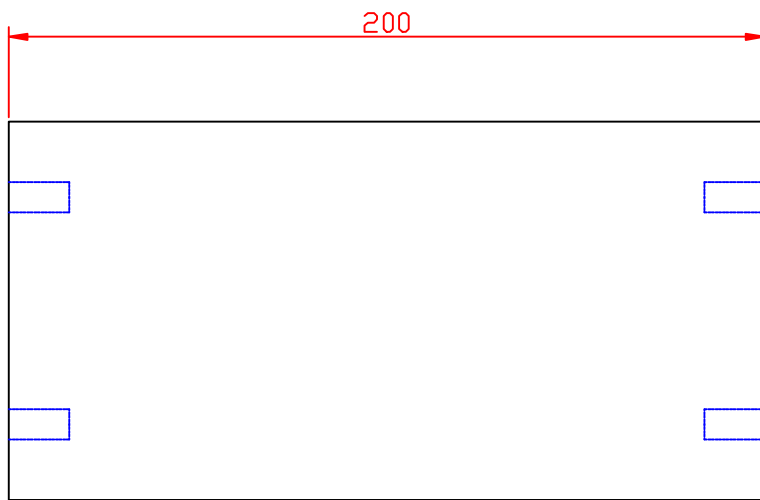

Alumno Pmm1

2012/05/17



PMM1



C.I.F.P. Pico Frentes
SORIA

ESCALA

1:8

DESPIECE -ZOCALO

LAMINA

4.6

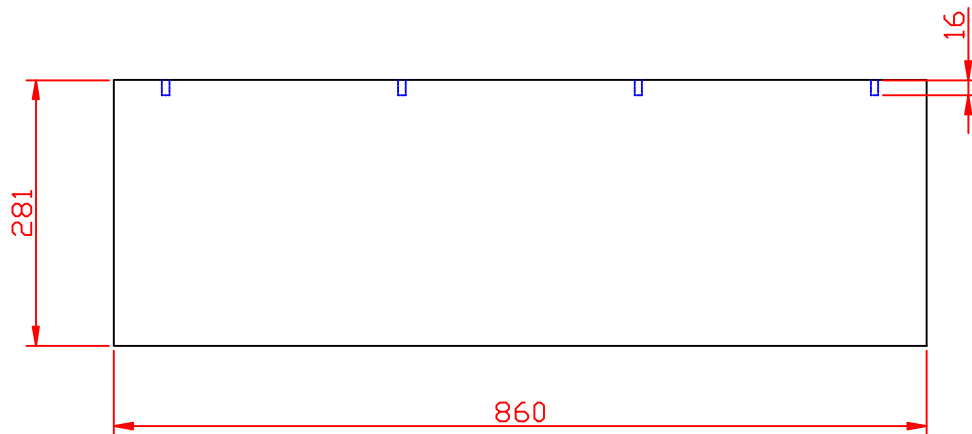
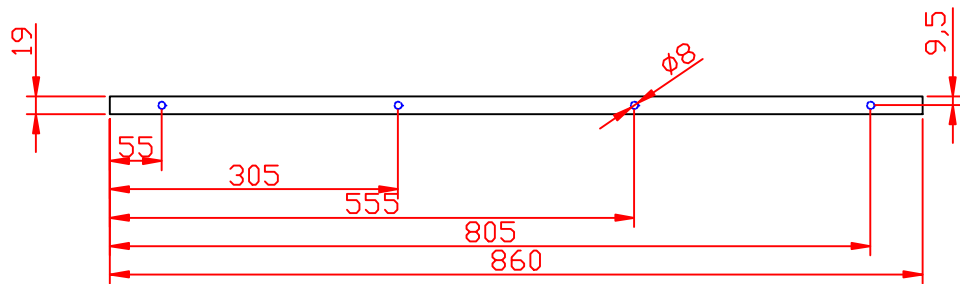

Alumno Pmm1



C.I.F.P. Pico Frentes
SORIA

2012/05/17

PMM1

ESCALA

LAMINA

1:5

DESPIECE -BANDEJA

4.7

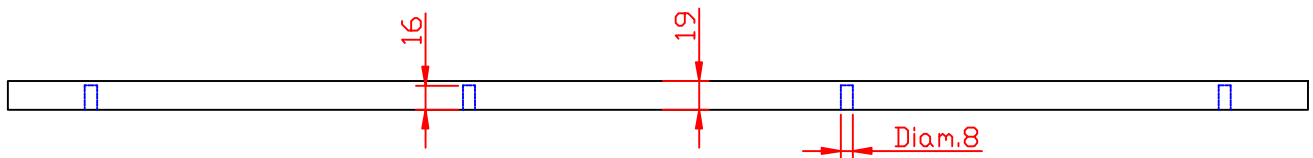
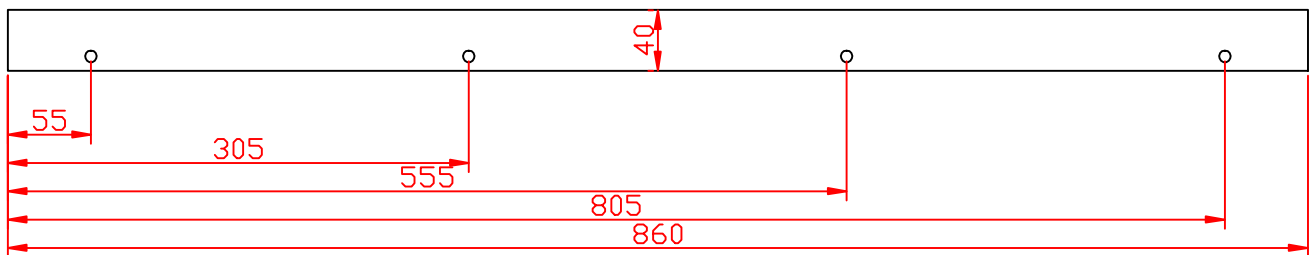

Alumno Pmm1

2012/05/17



PMM1



**C.I.F.P. Pico Frentes
SORIA**

ESCALA

1:5

LAMINA

DESPIECE -RESGUARDO

4.8

RASTEX 15
para tableros de 19 mm

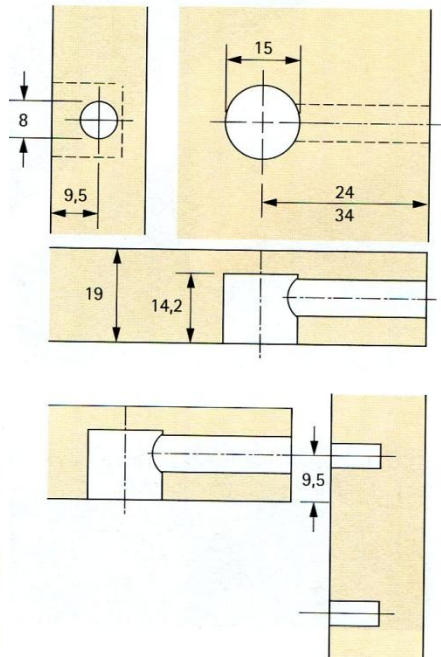

Taco expandible con bola de nylon
para rosca M6 y taladro \varnothing 8 mm,
Latón pulido

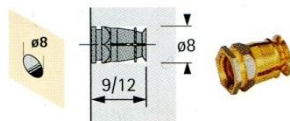

Longitud	Código	U.E.
9 mm	079 537	200
12 mm	079 538	200

Listado Escandallo

Listado Combinado

Fecha:













17/05/2012 jueves

Primer nivel

Código: MSG-750*600*1200RO

Descripción: MESA-750*600*1200ROBLE

Características [MESA GDP - CONJUNTO].ALTO=750
 [MESA GDP - CONJUNTO].ANCHO=600
 [MESA GDP - CONJUNTO].LARGO=1200
 [MESA GDP - CONJUNTO].COLOR FORMACION=ROBLE

N	Código	Descripción	Dimensiones / Tiempos	C.Neta	Cantidad	Ud
1	 SOG-1200*600RO	SOBRE-1200*600ROBLE	600	1	1	u
1	 LAG-715*560RO	LATERAL-715*560ROBLE	560	2	2	u
1	 TRG-1082*400RO	TRASERA-1082*400ROBLE	400	1	1	u
1	 BAG-200*501RO	BALDA-200*501ROBLE	501	1	1	u
1	 ZOG-200*100RO	ZOCALO-200*100ROBLE	100	2	2	u
1	 SEG-715*501RO	SEPARADOR-715*501ROBLE	501	1	1	u
1	 POG-40*300*860RO	PORTANTE-40*300*860ROBLE	300x40	1	1	u
1	 MPI4731	MANUAL INSTRUCCIONES		1	1	u
1	 MAT00071	PATAS DIAMETRO 15X5		6	6	u
1	 MPHGU3190	GUIA METALICA 250 mm PARA BANDEJA		2	2	u
1	 MPH0H3268	ESPIGA		8	8	u
1	 MPHPM4723	CONJUNTO RASTEX		14	14	u
1	 OPEM001	EMBALAR	1,6 Min	1	1	

F.P. SORIA

Listado de Órdenes de Fabricación

17/05/2012

N.OF.: 12000001

F.Creación: 17/05/2012

Origen: Fabricacion

Estado: Lanzada

Tipo: Normal

Lanz.: 1200001

Artículo: SOG-1200*600RO

Desc.Art.: SOBRE-1200*600ROBLE

Grupo: 1200001

C.Inic: 1,00

C.Actual: 0,00

C.Límite:

C.Especiales: 0

Almacén: PRODUCTO TERMINADO



F. Inicio: 17/05/2012





F. Prevista Fin: 17/05/2012

Traz.:

Dim.: 600

Ord. P.: 12000010

Orígenes de la Orden: Nec.x1ud

O.F. Tipo	Código/Descripción	C.Unit	Cant.	C.Usada U.M.	Destino	Dest. Operación	Observaciones	Cant	Tpo
	MPTM3431 TABLERO MEL. ROBLE 30MM.(ESTÁNDAR)	0,74	0,74	0,00 m²	AUXILIARES		Dim:(1200 +10)x(600 +10)		
	OPSE004 CORTAR	0,13	0,13	0,00 min	AUXILIARES	AUXILIARES		<input type="text"/>	<input type="text"/> 
	MPCP3559 CANTO ROBLE PVC 32 mm.	3,72	3,72	0,00 m	AUXILIARES		Dim:(1200 +30+ 600 +30)x2		
	OPPR001 PREPARAR CNC	0,34	0,34	0,00 min	CNC'S	CNC'S		<input type="text"/>	<input type="text"/> 
	OPME001 MECANIZAR EN CNC	1,61	1,61	0,00 min	PRODUCTO TERMINADO	CNC'S		<input type="text"/>	<input type="text"/> 

F.P. SORIA

Listado de Órdenes de Fabricación

17/05/2012

N.OF.: 12000002

F.Creación: 17/05/2012

Origen: Fabricacion

Estado: Lanzada

Tipo: Normal

Lanz.: 1200001

Artículo: LAG-715*560RO

Desc.Art.: LATERAL-715*560ROBLE

Grupo: 1200001

C.Inic: 2,00

C.Actual: 0,00

C.Límite:

C.Especiales: 0

Almacén: PRODUCTO TERMINADO



F. Inicio: 17/05/2012









F. Prevista Fin: 17/05/2012

Traz.:

Dim.: 560

Ord. P.: 12000010

Orígenes de la Orden: Nec.x2 uds

O.F. Tipo	Código/Descripción	C.Unit	Cant.	C.Usada U.M.	Destino	Dest. Operación	Observaciones	Cant	Tpo
	MPTM0447 C1: TABLERO MEL. ROBLE P06 2C/TF 3660x2100x19MM.(ESTÁNDAR)	0,46	0,92	0,00 m²	CORTE		Dim:(715 +10)x(560 +10)		
	COR19 CORTAR TABLERO DE 19 MM	0,00	0,00	0,00 min	CHAPADO MANUAL	CORTE		<input type="text"/>	<input type="text"/> 
	MPCP3560 C1: CANTO ROBLE PVC 22 mm.	1,49	2,98	0,00 m	CHAPADO MANUAL		Dim:(715 +30)x2		
	OPPR001 PREPARAR CNC	0,34	0,68	0,00 min	CNC'S	CNC'S		<input type="text"/>	<input type="text"/> 
	OPME001 MECANIZAR EN CNC	1,61	3,22	0,00 min	PRODUCTO TERMINADO	CNC'S		<input type="text"/>	<input type="text"/> 

F.P. SORIA

Listado de Órdenes de Fabricación

17/05/2012

N.OF.: 12000003

F.Creación: 17/05/2012

Origen: Fabricacion

Estado: Lanzada

Tipo: Normal

Lanz.: 1200001









Artículo: TRG-1082*400RO	Desc.Art.: TRASERA-1082*400ROBLE			
C.Inic: 1,00	C.Actual: 0,00	C.Límite:	C.Especiales: 0	Almacén: PRODUCTO TERMINADO
F. Inicio: 17/05/2012	F. Prevista Fin: 17/05/2012	Traz.:	Dim.: 400	

Grupo: 1200001



Ord. P.: 12000010

Orígenes de la Orden: Nec.x1ud

O.F. Tipo	Código/Descripción	C.Unit	Cant.	C.Usada U.M.	Destino	Dest. Operación	Observaciones	Cant	Tpo
	MPTM0447 C1: TABLERO MEL. ROBLE P06 2C/TF 3660x2100x19MM.(ESTÁNDAR)	0,50	0,50	0,00 m²	CORTE		Dim:(1082 +10)x(400 +10)		
	COR19 CORTAR TABLERO DE 19 MM	0,00	0,00	0,00 min	CHAPADO MANUAL	CORTE		<input type="text"/>	<input type="text"/> 
	MPCP3560 C1: CANTO ROBLE PVC 22 mm.	1,11	1,11	0,00 m	CHAPADO MANUAL		Dim:(1082 +30)		
	OPPR001 PREPARAR CNC	0,34	0,34	0,00 min	CNC'S	CNC'S		<input type="text"/>	<input type="text"/> 
	OPME001 MECANIZAR EN CNC	1,61	1,61	0,00 min	PRODUCTO TERMINADO	CNC'S		<input type="text"/>	<input type="text"/> 

F.P. SORIA

Listado de Órdenes de Fabricación

17/05/2012

N.OF.: 12000004

F.Creación: 17/05/2012

Origen: Fabricacion

Estado: Lanzada

Tipo: Normal

Lanz.: 1200001









Artículo: BAG-200*501RO		Desc.Art.: BALDA-200*501ROBLE			
C.Inic: 1,00	C.Actual: 0,00	C.Límite:	C.Especiales: 0	Almacén: PRODUCTO TERMINADO	
F. Inicio: 17/05/2012	F. Prevista Fin: 17/05/2012	Traz.:	Dim.: 501		

Grupo: 1200001



Ord. P.: 12000010

Orígenes de la Orden: Nec.x1ud

O.F. Tipo	Código/Descripción	C.Unit	Cant.	C.Usada U.M.	Destino	Dest. Operación	Observaciones	Cant	Tpo
	MPTM0447 C1: TABLERO MEL. ROBLE P06 2C/TF 3660x2100x19MM.(ESTÁNDAR)	0,12	0,12	0,00 m²	CORTE		Dim:(200 +10)x(501 +10)		
	COR19 CORTAR TABLERO DE 19 MM	0,00	0,00	0,00 min	CHAPADO MANUAL	CORTE		<input type="text"/>	<input type="text"/> 
	MPCP3560 C1: CANTO ROBLE PVC 22 mm.	0,46	0,46	0,00 m	CHAPADO MANUAL		Dim:(200 +30)x2		
	OPPR001 PREPARAR CNC	0,34	0,34	0,00 min	CNC'S	CNC'S		<input type="text"/>	<input type="text"/> 
	OPME001 MECANIZAR EN CNC	1,61	1,61	0,00 min	PRODUCTO TERMINADO	CNC'S		<input type="text"/>	<input type="text"/> 

F.P. SORIA

Listado de Órdenes de Fabricación

17/05/2012

N.OF.: 12000005

F.Creación: 17/05/2012

Origen: Fabricacion

Estado: Lanzada

Tipo: Normal

Lanz.: 1200001







Artículo: ZOG-200*100RO		Desc.Art.: ZOCALO-200*100ROBLE			
C.Inic: 2,00	C.Actual: 0,00	C.Límite:	C.Especiales: 0	Almacén: PRODUCTO TERMINADO	
F. Inicio: 17/05/2012	F. Prevista Fin: 17/05/2012	Traz.:	Dim.: 100		

Grupo: 1200001



Ord. P.: 12000010

Orígenes de la Orden: Nec.x2 uds

O.F. Tipo	Código/Descripción	C.Unit	Cant.	C.Usada U.M.	Destino	Dest. Operación	Observaciones	Cant	Tpo
	MPTM0447 C1: TABLERO MEL. ROBLE P06 2C/TF 3660x2100x19MM.(ESTÁNDAR)	0,02	0,04	0,00 m²	CORTE		Dim:(200 +10)x(100 +10)		
	COR19 CORTAR TABLERO DE 19 MM	0,00	0,00	0,00 min	CNC'S	CORTE		<input type="text"/>	<input type="text"/> 
	OPPR001 PREPARAR CNC	0,34	0,68	0,00 min	CNC'S	CNC'S		<input type="text"/>	<input type="text"/> 
	OPME001 MECANIZAR EN CNC	1,61	3,22	0,00 min	PRODUCTO TERMINADO	CNC'S		<input type="text"/>	<input type="text"/> 

F.P. SORIA

Listado de Órdenes de Fabricación

17/05/2012

N.OF.: 12000006

F.Creación: 17/05/2012

Origen: Fabricacion

Estado: Lanzada

Tipo: Normal

Lanz.: 1200001









Artículo: SEG-715*501RO	Desc.Art.: SEPARADOR-715*501ROBLE			
C.Inic: 1,00	C.Actual: 0,00	C.Límite:	C.Especiales: 0	Almacén: PRODUCTO TERMINADO
F. Inicio: 17/05/2012	F. Prevista Fin: 17/05/2012	Traz.:	Dim.: 501	

Grupo: 1200001



Ord. P.: 12000010

Orígenes de la Orden: Nec.x1ud

O.F. Tipo	Código/Descripción	C.Unit	Cant.	C.Usada U.M.	Destino	Dest. Operación	Observaciones	Cant	Tpo
	MPTM0447 C1: TABLERO MEL. ROBLE P06 2C/TF 3660x2100x19MM.(ESTÁNDAR)	0,41	0,41	0,00 m²	CORTE		Dim:(715 +10)x(501 +10)		
	COR19 CORTAR TABLERO DE 19 MM	0,00	0,00	0,00 min	CHAPADO MANUAL	CORTE		<input type="text"/>	<input type="text"/> 
	MPCP3560 C1: CANTO ROBLE PVC 22 mm.	1,49	1,49	0,00 m	CHAPADO MANUAL		Dim:(715 +30)x2		
	OPPR001 PREPARAR CNC	0,34	0,34	0,00 min	CNC'S	CNC'S		<input type="text"/>	<input type="text"/> 
	OPME001 MECANIZAR EN CNC	1,61	1,61	0,00 min	PRODUCTO TERMINADO	CNC'S		<input type="text"/>	<input type="text"/> 

F.P. SORIA

Listado de Órdenes de Fabricación

17/05/2012

N.OF.: 12000007

F.Creación: 17/05/2012

Origen: Fabricacion

Estado: Lanzada

Tipo: Normal

Lanz.: 1200001









Artículo: BNG-860*281RO	Desc.Art.: BANDEJA-860*281ROBLE			
C.Inic: 1,00	C.Actual: 0,00	C.Límite:	C.Especiales: 0	Almacén: PRODUCTO TERMINADO
F. Inicio: 17/05/2012	F. Prevista Fin: 17/05/2012	Traz.:	Dim.: 281	

Grupo: 1200001



Ord. P.: 12000009

Orígenes de la Orden: Nec.x1ud

O.F. Tipo	Código/Descripción	C.Unit	Cant.	C.Usada U.M.	Destino	Dest. Operación	Observaciones	Cant	Tpo
	MPTM0447 C1: TABLERO MEL. ROBLE P06 2C/TF 3660x2100x19MM.(ESTÁNDAR)	0,28	0,28	0,00 m²	CORTE		Dim:(860 +10)x(281 +10)		
	COR19 CORTAR TABLERO DE 19 MM	0,00	0,00	0,00 min	CHAPADO MANUAL	CORTE		<input type="text"/>	<input type="text"/> 
	MPCP3560 C1: CANTO ROBLE PVC 22 mm.	1,51	1,51	0,00 m	CHAPADO MANUAL		Dim:(860 +30)+(281 +30)x2		
	OPPR001 PREPARAR CNC	0,34	0,34	0,00 min	CNC'S	CNC'S		<input type="text"/>	<input type="text"/> 
	OPME001 MECANIZAR EN CNC	1,61	1,61	0,00 min	PRODUCTO TERMINADO	CNC'S		<input type="text"/>	<input type="text"/> 

F.P. SORIA

Listado de Órdenes de Fabricación

17/05/2012

N.OF.: 12000008

F.Creación: 17/05/2012

Origen: Fabricacion

Estado: Lanzada

Tipo: Normal

Lanz.: 1200001

Artículo: SOG-860*40RO

Desc.Art.: SOPORTE-860*40ROBLE

Grupo: 1200001

C.Inic: 1,00

C.Actual: 0,00

C.Límite:

C.Especiales: 0

Almacén: PRODUCTO TERMINADO



F. Inicio: 17/05/2012









F. Prevista Fin: 17/05/2012

Traz.:

Dim.: 40

Ord. P.: 12000009

Orígenes de la Orden: Nec.x1ud

O.F. Tipo	Código/Descripción	C.Unit	Cant.	C.Usada U.M.	Destino	Dest. Operación	Observaciones	Cant	Tpo
	MPTM0447 C1: TABLERO MEL. ROBLE P06 2C/TF 3660x2100x19MM.(ESTÁNDAR)	0,00	0,00	0,00 m²	CORTE		Dim:(860 +30)x2		
	COR19 CORTAR TABLERO DE 19 MM	0,00	0,00	0,00 min	CHAPADO MANUAL	CORTE		<input type="text"/>	<input type="text"/> 
	MPCP3560 C1: CANTO ROBLE PVC 22 mm.	1,03	1,03	0,00 m	CHAPADO MANUAL		Dim:(860 +30)+(40 +30)x2		
	OPPR001 PREPARAR CNC	0,34	0,34	0,00 min	CNC'S	CNC'S		<input type="text"/>	<input type="text"/> 
	OPME001 MECANIZAR EN CNC	1,61	1,61	0,00 min	PRODUCTO TERMINADO	CNC'S		<input type="text"/>	<input type="text"/> 

F.P. SORIA

Listado de Órdenes de Fabricación

17/05/2012

N.OF.: 12000009

F.Creación: 17/05/2012

Origen: Fabricacion

Estado: Lanzada

Tipo: Normal

Lanz.: 1200001

Artículo: POG-40*300*860RO

Desc.Art.: PORTANTE-40*300*860ROBLE

Grupo: 1200001

C.Inic: 1,00

C.Actual: 0,00

C.Límite:

C.Especiales: 0

Almacén: PRODUCTO TERMINADO



F. Inicio: 17/05/2012

F. Prevista Fin: 17/05/2012

Traz.:

Dim.: 300x40

Ord. P.: 12000010

Orígenes de la Orden: Nec.x1ud

O.F. Tipo	Código/Descripción	C.Unit	Cant.	C.Usada U.M.	Destino	Dest. Operación	Observaciones	Cant	Tpo
	BNG-860*281RO BANDEJA-860*281ROBLE	1,00	1,00	0,00 u	MONTAJE Y EMBALAJE		Dim:281		
	SOG-860*40RO SOPORTE-860*40ROBLE	1,00	1,00	0,00 u	MONTAJE Y EMBALAJE		Dim:40		
	MPHOH3268 ESPIGA	4,00	4,00	0,00 u	MONTAJE Y EMBALAJE				
	OPPG001 ENCOLAR	0,50	0,50	0,00 min	PRODUCTO TERMINADO	MONTAJE Y EMBALAJE		<input type="text"/>	<input type="text"/>



F.P. SORIA

Listado de Órdenes de Fabricación

17/05/2012

N.OF.: 12000010

F.Creación: 17/05/2012

Origen: Manual

Estado: Lanzada

Tipo: Normal

Lanz.: 1200001

Artículo: MSG-750*600*1200RO

Desc.Art.: MESA-750*600*1200ROBLE

Grupo: 1200001

C.Inic: 1,00

C.Actual: 0,00

C.Límite:

C.Especiales: 0

Almacén: PRODUCTO TERMINADO



F. Inicio: 17/05/2012

F. Prevista Fin: 17/05/2012

Traz.:

Dim.: 600x750

Orígenes de la Orden: Nec.x1ud

O.F. Tipo	Código/Descripción	C.Unit	Cant.	C.Usada U.M.	Destino	Dest. Operación	Observaciones	Cant	Tpo
	SOG-1200*600RO SOBRE-1200*600ROBLE	1,00	1,00	0,00 u	MONTAJE Y EMBALAJE		Dim:600		
	LAG-715*560RO LATERAL-715*560ROBLE	2,00	2,00	0,00 u	MONTAJE Y EMBALAJE		Dim:560		
	TRG-1082*400RO TRASERA-1082*400ROBLE	1,00	1,00	0,00 u	MONTAJE Y EMBALAJE		Dim:400		
	BAG-200*501RO BALDA-200*501ROBLE	1,00	1,00	0,00 u	MONTAJE Y EMBALAJE		Dim:501		
	ZOG-200*100RO ZOCALO-200*100ROBLE	2,00	2,00	0,00 u	MONTAJE Y EMBALAJE		Dim:100		
	SEG-715*501RO SEPARADOR-715*501ROBLE	1,00	1,00	0,00 u	MONTAJE Y EMBALAJE		Dim:501		
	POG-40*300*860RO PORTANTE-40*300*860ROBLE	1,00	1,00	0,00 u	MONTAJE Y EMBALAJE		Dim:300x40		
	MPI4731 MANUAL INSTRUCCIONES	1,00	1,00	0,00 u	MONTAJE Y EMBALAJE				
	MAT00071 PATAS DIAMETRO 15X5	6,00	6,00	0,00 u	MONTAJE Y EMBALAJE				
	MPHGU3190 GUIA METALICA 250 mm PARA BANDEJA	2,00	2,00	0,00 u	MONTAJE Y EMBALAJE				
	MPHOH3268 ESPIGA	8,00	8,00	0,00 u	MONTAJE Y EMBALAJE				
	MPHPM4723 CONJUNTO RASTEX	14,00	14,00	0,00 u	MONTAJE Y EMBALAJE				
	OPEM001 EMBALAR	1,60	1,60	0,00 min	PRODUCTO TERMINADO	MONTAJE Y EMBALAJE			



AIDIMA
 C.I.F. G46261590
 CALLE BENJAMIN FRANKLIN 13
 PARQUE TECNOLOGICO
 46980 PATERNA - VALENCIA (ESPAÑA)
 Tel: 96 136 60 70 - 96 136 61 71
 vleon@aidima.es

PEDIDO A PROVEEDOR	
Nº Pedido:	A1200001
Entrega Prevista:	17/05/12
Fecha:	17/05/12

Página 1 de 1

LUGAR DE ENTREGA:
 AIDIMA - ALMACEN MUESTRAS
 CALLE BENJAMIN FRANKLIN 13
 PARQUE TECNOLOGICO
 46980 PATERNA - VALENCIA (ESPAÑA)
 Tel: 96 136 60 70 Fax: 96 136 61 71

PROVEEDOR: 000005
 MADERAS VICTOR
 CALLE LOS ROBLES 15
 40022 SORIA - SEGOVIA (ESPAÑA)
 Tel: 9752500279 Fax: 9752500279
 C.I.F.:71291550L

ARTÍCULO	CANTIDAD	Ud.	DESCRIPCIÓN ARTICULO
MPTM3431	1	m ²	TABLERO MEL. ROBLE 30MM.(ESTÁNDAR)



OBSERVACIONES:	TÉRMINOS DE ENTREGA:PORTES PAGADOS	
	FORMA DE PAGO: CONTADO	
	Confirmación propia:	Confirmación proveedor:
	Fecha	Fecha
¡¡¡ NOTA MUY IMPORTANTE !!! El horario de descargas será de 7:00 h. a 12:00 h.		

AIDIMA
 C.I.F. G46261590
 CALLE BENJAMIN FRANKLIN 13
 PARQUE TECNOLOGICO
 46980 PATERNA - VALENCIA (ESPAÑA)
 Tel: 96 136 60 70 - 96 136 61 71
 vleon@aidima.es

PEDIDO A PROVEEDOR	
Nº Pedido:	A1200002
Entrega Prevista:	28/05/12
Fecha:	17/05/12

Página 1 de 1

LUGAR DE ENTREGA:

AIDIMA - ALMACEN MUESTRAS
 CALLE BENJAMIN FRANKLIN 13
 PARQUE TECNOLOGICO
 46980 PATERNA - VALENCIA (ESPAÑA)
 Tel: 96 136 60 70 Fax: 96 136 61 71

PROVEEDOR: 000032

Maderas Gómez
 CALLE VEGA 44
 26200 HARO - LA RIOJA (ESPAÑA)
 Tel: 943123455 Fax: 943140333
 C.I.F.:7565885

Cir/07/03/2008 Vacaciones de Semana Santa del 19 al 28 de Marzo 2

ARTÍCULO	CANTIDAD	Ud.	DESCRIPCIÓN ARTICULO
MPCP3559	4	m	CANTO ROBLE PVC 32 MM.
MPCP3560	9	m	CANTO ROBLE PVC 22 MM.



OBSERVACIONES:	TÉRMINOS DE ENTREGA:PORTES PAGADOS	
	FORMA DE PAGO: REPOSICIÓN A 90 DÍAS	
	Confirmación propia:	Confirmación proveedor:
	Fecha	Fecha
¡¡¡ NOTA MUY IMPORTANTE !!! El horario de descargas será de 7:00 h. a 12:00 h.		

AIDIMA
 C.I.F. G46261590
 CALLE BENJAMIN FRANKLIN 13
 PARQUE TECNOLOGICO
 46980 PATERNA - VALENCIA (ESPAÑA)
 Tel: 96 136 60 70 - 96 136 61 71
 vleon@aidima.es

PEDIDO A PROVEEDOR	
Nº Pedido:	A1200003
Entrega Prevista:	21/05/12
Fecha:	17/05/12

Página 1 de 1

LUGAR DE ENTREGA:
 AIDIMA - ALMACEN MUESTRAS
 CALLE BENJAMIN FRANKLIN 13
 PARQUE TECNOLOGICO
 46980 PATERNA - VALENCIA (ESPAÑA)
 Tel: 96 136 60 70 Fax: 96 136 61 71

PROVEEDOR: 000194
 EMUCA, S.A
 POL. INDUSTRIAL El Oliveral Calle/H 4
 APDO CORREOS 176
 46190 RIBARROJA DEL TURIA - VALENCIA (ESPAÑA)
 Tel: 961667019 Fax: 961667182
 C.I.F.:A46154704
 01/01/2008 AUMENTO PRECIOS DEL 4%. CIR/15/12/07

ARTÍCULO	CANTIDAD	Ud.	DESCRIPCIÓN ARTICULO
MAT00071	6	u	PATAS DIAMETRO 15X5
MPHGU3190	2	u	GUIA METALICA 250 MM PARA BANDEJA
MPHPM4723	14	u	CONJUNTO RASTEX



OBSERVACIONES:	TÉRMINOS DE ENTREGA:PORTES PAGADOS	
	FORMA DE PAGO: REPOSICIÓN A 90 DÍAS	
	Confirmación propia:	Confirmación proveedor:
	Fecha	Fecha
¡¡¡ NOTA MUY IMPORTANTE !!! El horario de descargas será de 7:00 h. a 12:00 h.		

AIDIMA
 C.I.F. G46261590
 CALLE BENJAMIN FRANKLIN 13
 PARQUE TECNOLOGICO
 46980 PATERNA - VALENCIA (ESPAÑA)
 Tel: 96 136 60 70 - 96 136 61 71
 vleon@aidima.es

PEDIDO A PROVEEDOR	
Nº Pedido:	A1200004
Entrega Prevista:	24/05/12
Fecha:	17/05/12

Página 1 de 1

LUGAR DE ENTREGA:

AIDIMA - ALMACEN MUESTRAS
 CALLE BENJAMIN FRANKLIN 13
 PARQUE TECNOLOGICO
 46980 PATERNA - VALENCIA (ESPAÑA)
 Tel: 96 136 60 70 Fax: 96 136 61 71

PROVEEDOR: 000447

BLAU VERD IMPRESSORS,S.L
 AVENIDA RIBERA ALTA 22
 46293 ALCANTERA DE XUQUER - VALENCIA (ESPAÑA)
 Tel: 962580827 Fax: 962976122
 C.I.F.:B96723697

REPETICION DE 1000 TAMAÑO 23X34 A 0,07663€-----0,08275€

ARTÍCULO	CANTIDAD	Ud.	DESCRIPCIÓN ARTICULO
MPI4731	100	u	MANUAL INSTRUCCIONES

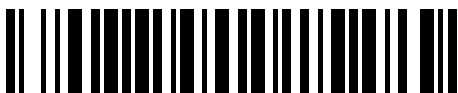

OBSERVACIONES:	TÉRMINOS DE ENTREGA:PORTES PAGADOS	
	FORMA DE PAGO: REPOSICIÓN A 60 DÍAS	
	Confirmación propia:	Confirmación proveedor:
	Fecha	Fecha
¡¡¡ NOTA MUY IMPORTANTE !!! El horario de descargas será de 7:00 h. a 12:00 h.		

AIDIMA
 C.I.F. G46261590
 CALLE BENJAMIN FRANKLIN 13
 PARQUE TECNOLOGICO
 46980 PATERNA - VALENCIA (ESPAÑA)
 Tel: 96 136 60 70 - 96 136 61 71
 vleon@aidima.es

PEDIDO A PROVEEDOR	
Nº Pedido:	A1200005
Entrega Prevista:	07/06/12
Fecha:	17/05/12

Página 1 de 1

LUGAR DE ENTREGA:

AIDIMA - PLANTA PILOTO
 CALLE BENJAMIN FRANKLIN 13
 PARQUE TECNOLOGICO
 46980 PATERNA - VALENCIA (ESPAÑA)
 Tel: 96 136 60 70 Fax: 96 136 61 71

PROVEEDOR: 001606

TABLEROS TRADEMA, S.L
 CALLE CASTELL, 2-2ª
 46460 SILLA - VALENCIA (ESPAÑA)
 Tel: 961217280 Fax: 961212559
 C.I.F.:B81599052

ARTÍCULO	CANTIDAD	Ud.	DESCRIPCIÓN ARTICULO
M458/M458 TF/TF	22	u	ROBLE TIGRE



OBSERVACIONES:	TÉRMINOS DE ENTREGA:PORTES PAGADOS	
	FORMA DE PAGO: REPOSICIÓN A 60 DÍAS	
	Confirmación propia:	Confirmación proveedor:
	Fecha	Fecha
¡¡¡ NOTA MUY IMPORTANTE !!! El horario de descargas será de 7:00 h. a 12:00 h.		

Lanzamiento: 1200001

Prep	Código	Artículo	Cód.Embarque	Cantidad	F.	F.Prev.	Especial
Si	12000001	SOG-1200*600RO		1	17/05/12	17/05/12	<input type="checkbox"/>
Si	12000002	LAG-715*560RO		2	17/05/12	17/05/12	<input type="checkbox"/>
Si	12000003	TRG-1082*400RO		1	17/05/12	17/05/12	<input type="checkbox"/>
Si	12000004	BAG-200*501RO		1	17/05/12	17/05/12	<input type="checkbox"/>
Si	12000005	ZOG-200*100RO		2	17/05/12	17/05/12	<input type="checkbox"/>
Si	12000006	SEG-715*501RO		1	17/05/12	17/05/12	<input type="checkbox"/>
Si	12000007	BNG-860*281RO		1	17/05/12	17/05/12	<input type="checkbox"/>
Si	12000008	SOG-860*40RO		1	17/05/12	17/05/12	<input type="checkbox"/>
No	12000009	POG-40*300*860RO		1	17/05/12	17/05/12	<input type="checkbox"/>
No	12000010	MSG-750*600*1200RO		1	17/05/12	17/05/12	<input type="checkbox"/>

La generación de órdenes de fabricación ha finalizado con éxito

Órdenes de fabricación GENERADAS por Necesidades:

OF N°:12000001	Grupo: 1200001	1xSOG-1200*600RO	SOBRE-1200*600ROBLE
OF N°:12000002	Grupo: 1200001	2xLAG-715*560RO	LATERAL-715*560ROBLE
OF N°:12000003	Grupo: 1200001	1xTRG-1082*400RO	TRASERA-1082*400ROBLE
OF N°:12000004	Grupo: 1200001	1xBAG-200*501RO	BALDA-200*501ROBLE
OF N°:12000005	Grupo: 1200001	2xZOG-200*100RO	ZOCALO-200*100ROBLE
OF N°:12000006	Grupo: 1200001	1xSEG-715*501RO	SEPARADOR-715*501ROBLE
OF N°:12000007	Grupo: 1200001	1xBNG-860*281RO	BANDEJA-860*281ROBLE
OF N°:12000008	Grupo: 1200001	1xSOG-860*40RO	SOPORTE-860*40ROBLE
OF N°:12000009	Grupo: 1200001	1xPOG-40*300*860RO	PORTANTE-40*300*860ROBLE
OF N°:12000010	Grupo: 1200001	1xMSG-750*600*1200RO	MESA-750*600*1200ROBLE

ATENCIÓN: Se han generado necesidades de compra de artículos:

MPTM3431 TABLERO MEL. ROBLE 30MM.(ESTÁNDAR) 0,74 m²
MPCP3559 CANTO ROBLE PVC 32 mm. 3,72 m
MPTM0447 TABLERO MEL. ROBLE P06 2C/TF 3660x2100x19MM.(ESTÁNDAR) 0,92 m²
MPCP3560 CANTO ROBLE PVC 22 mm. 2,98 m
MPTM0447 TABLERO MEL. ROBLE P06 2C/TF 3660x2100x19MM.(ESTÁNDAR) 0,5 m²
MPCP3560 CANTO ROBLE PVC 22 mm. 1,11 m
MPTM0447 TABLERO MEL. ROBLE P06 2C/TF 3660x2100x19MM.(ESTÁNDAR) 0,12 m²
MPCP3560 CANTO ROBLE PVC 22 mm. 0,46 m
MPTM0447 TABLERO MEL. ROBLE P06 2C/TF 3660x2100x19MM.(ESTÁNDAR) 0,04 m²
MPTM0447 TABLERO MEL. ROBLE P06 2C/TF 3660x2100x19MM.(ESTÁNDAR) 0,41 m²
MPCP3560 CANTO ROBLE PVC 22 mm. 1,49 m
MPTM0447 TABLERO MEL. ROBLE P06 2C/TF 3660x2100x19MM.(ESTÁNDAR) 0,28 m²
MPCP3560 CANTO ROBLE PVC 22 mm. 1,51 m
MPCP3560 CANTO ROBLE PVC 22 mm. 1,03 m
MPI4731 MANUAL INSTRUCCIONES 1 u
MAT00071 PATAS DIAMETRO 15X5 6 u
MPHGU3190 GUIA METALICA 250 mm PARA BANDEJA 2 u
MPHPM4723 CONJUNTO RASTEX 14 u

Lanzamiento Nº: 1200001

Observ. Lanz.: ejemplo mesa

Sección Destino: CORTE

Cod.Artículo	Artículo				Cantidad Reservada	Cantidad Necesaria	UM	Cantidad Recogida	Faltas	Necesidad
MPTM0447	TABLERO MEL. ROBLE P06 2C/TF 3660x2100x19MM.(ESTÁNDAR)				2,27	2,27	m²			0,00
Ub.Recogida	O.F.	C.Reservada	C.Necesaria	C.Recogida	Faltas	Necesid.	Observaciones			
TABLEROS <LIBRE>	12000002	0,92	0,92			0,00				
TABLEROS <LIBRE>	12000003	0,50	0,50			0,00				
TABLEROS <LIBRE>	12000004	0,12	0,12			0,00				
TABLEROS <LIBRE>	12000005	0,04	0,04			0,00				
TABLEROS <LIBRE>	12000006	0,41	0,41			0,00				
TABLEROS <LIBRE>	12000007	0,28	0,28			0,00				

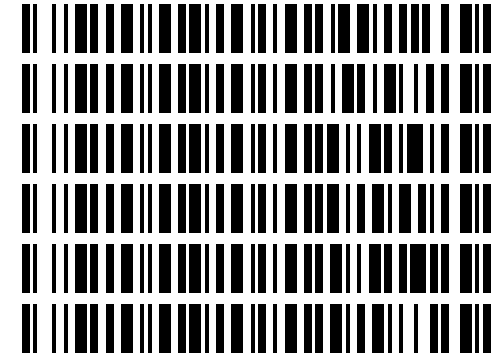

ORDENES DE TRABAJO: (CORTE)

Lanzamiento nº: 1200001
ejemplo mesa

F.P. SORIA

17/05/2012

Reales
Cant.

Artículo	Código	Nº OF	Cantidad	Tpo (min)	Observaciones
----------	--------	-------	----------	-----------	---------------

CORTAR TABLERO DE 19 MM [COR19] --> TABLERO MEL. ROBLE P06 2C/TF 3660x2100x19MM.(ESTÁNDAR)

LATERAL-715*560ROBLE

LAG-715*560RO

12000002

2

0



TRASERA-1082*400ROBLE

TRG-1082*400RO

12000003

1

0



BALDA-200*501ROBLE

BAG-200*501RO

12000004

1

0



ZOCALO-200*100ROBLE

ZOG-200*100RO

12000005

2

0



SEPARADOR-715*501ROBLE

SEG-715*501RO

12000006

1

0



BANDEJA-860*281ROBLE

BNG-860*281RO

12000007

1

0



SOPORTE-860*40ROBLE

SOG-860*40RO

12000008

1

0



Total:

9

0

ORDENES DE TRABAJO: (CHAPADORA)

F.P. SORIA

Lanzamiento nº: 1200001
ejemplo mesa

17/05/2012

Artículo	Código	Nº OF	Cant.	Dimensiones Netas			CL1		Tpo ' Observaciones	Reales Cant.
				Largo	Ancho	Alto	CC2	CC1		

CANTEAR TESTAS 22 MM [CAN22]

[MPCP3560] CANTO ROBLE PVC 22 mm.

LATERAL-715*560ROBLE										
	LAG-715*560RO	1200000	2	0	560	0			0	
TRASERA-1082*400ROBLE										
	TRG-1082*400RO	1200000	1	0	400	0			0	
BALDA-200*501ROBLE										
	BAG-200*501RO	1200000	1	0	501	0			0	
SEPARADOR-715*501ROBLE										
	SEG-715*501RO	1200000	1	0	501	0			0	
BANDEJA-860*281ROBLE										
	BNG-860*281RO	1200000	1	0	281	0			0	
SOPORTE-860*40ROBLE										
	SOG-860*40RO	1200000	1	0	40	0			0	
Total:			7						0	

ORDENES DE TRABAJO: (ESTANDAR)

Lanzamiento nº: 1200001

F.P. SORIA

17/05/2012

ejemplo mesa

Artículo	Código	Nº OF	Cantidad	Dimensiones Brutas			Dimensiones Netas			Tpo (min)	Observaciones	Reales
				Largo	Ancho	Alto	Largo	Ancho	Alto			Cant.

CANTEAR TESTAS [OPCH08]

SOBRE-1200*600ROBLE

SOG-1200*600RO

1200001

1

0

0

0

0

600

0

0,1



Total:

1

0,1

ORDENES DE TRABAJO: (ESTANDAR)

Lanzamiento nº: 1200001

F.P. SORIA

17/05/2012

ejemplo mesa

Artículo	Código	Nº OF	Cantidad	Dimensiones Brutas			Dimensiones Netas			Tpo (min)	Observaciones	Reales
				Largo	Ancho	Alto	Largo	Ancho	Alto			Cant.

CORTAR [OPSE004]

SOBRE-1200*600ROBLE

SOG-1200*600RO

12000001

1

0

0

0

0

600

0

0,13



Total:

1

0,13

ORDENES DE TRABAJO: (ESTANDAR)

F.P. SORIA

Lanzamiento nº: 1200001

17/05/2012

ejemplo mesa

Artículo	Código	Nº OF	Cantidad	Dimensiones Brutas			Dimensiones Netas			Tpo (min)	Observaciones	Reales Cant.
				Largo	Ancho	Alto	Largo	Ancho	Alto			
ENCOLAR [OPPG001]												
PORTANTE-40*300*860ROBLE												
	POG-40*300*860RO	12000009	1	0	0	0	0	300	40	0,5		
	BNG-860*281RO	BANDEJA-860*281ROBLE								1 u		
	SOG-860*40RO	SOPORTE-860*40ROBLE								1 u		
	MPHOH3268	ESPIGA								4 u		
Total:			1							0,5		

ORDENES DE TRABAJO: (ESTANDAR)

Lanzamiento nº: 1200001

F.P. SORIA

17/05/2012

ejemplo mesa

Artículo	Código	Nº OF	Cantidad	Dimensiones Brutas			Dimensiones Netas			Tpo (min)	Observaciones	Reales
				Largo	Ancho	Alto	Largo	Ancho	Alto			Cant.

EMBALAR [OPEM001]

MESA-750*600*1200ROBLE

MSG-750*600*1200RO

12000010

1

0

0

0

0

600

750



1,6



Total:

1

1,6







ORDENES DE TRABAJO: (ESTANDAR)

Lanzamiento nº: 1200001

F.P. SORIA

17/05/2012

ejemplo mesa

Artículo	Código	Nº OF	Cantidad	Dimensiones Brutas			Dimensiones Netas			Tpo (min)	Observaciones	Reales Cant.
				Largo	Ancho	Alto	Largo	Ancho	Alto			
MECANIZAR EN CNC [OPME001]												
BALDA-200*501ROBLE	BAG-200*501RO	12000004	1	0	0	0	0	501	0	1,61		<input data-bbox="1933 347 2045 411" type="text"/>
BANDEJA-860*281ROBLE	BNG-860*281RO	12000007	1	0	0	0	0	281	0	1,61		<input data-bbox="1933 491 2045 555" type="text"/>
LATERAL-715*560ROBLE	LAG-715*560RO	12000002	2	0	0	0	0	560	0	3,22		<input data-bbox="1933 635 2045 699" type="text"/>
SEPARADOR-715*501ROBLE	SEG-715*501RO	12000006	1	0	0	0	0	501	0	1,61		<input data-bbox="1933 778 2045 842" type="text"/>
SOBRE-1200*600ROBLE	SOG-1200*600RO	12000001	1	0	0	0	0	600	0	1,61		<input data-bbox="1933 938 2045 1002" type="text"/>
SOPORTE-860*40ROBLE	SOG-860*40RO	12000008	1	0	0	0	0	40	0	1,61		<input data-bbox="1933 1082 2045 1145" type="text"/>
TRASERA-1082*400ROBLE	TRG-1082*400RO	12000003	1	0	0	0	0	400	0	1,61		<input data-bbox="1933 1225 2045 1289" type="text"/>



ORDENES DE TRABAJO: (ESTANDAR)

Lanzamiento nº: 1200001

F.P. SORIA

17/05/2012

ejemplo mesa

Artículo	Código	Nº OF	Cantidad	Dimensiones Brutas			Dimensiones Netas			Tpo (min)	Observaciones	Reales Cant.
				Largo	Ancho	Alto	Largo	Ancho	Alto			
ZOCALO-200*100ROBLE	ZOG-200*100RO	12000005	2	0	0	0	0	100	0	3,22		
Total:			10							16,1		







ORDENES DE TRABAJO: (ESTANDAR)

Lanzamiento nº: 1200001

F.P. SORIA

17/05/2012

ejemplo mesa

Artículo	Código	Nº OF	Cantidad	Dimensiones Brutas			Dimensiones Netas			Tpo (min)	Observaciones	Reales Cant.
				Largo	Ancho	Alto	Largo	Ancho	Alto			
PREPARAR CNC [OPPR001]												
BALDA-200*501ROBLE	BAG-200*501RO	12000004	1	0	0	0	0	501	0	0,34		<input type="text"/>
BANDEJA-860*281ROBLE	BNG-860*281RO	12000007	1	0	0	0	0	281	0	0,34		<input type="text"/>
LATERAL-715*560ROBLE	LAG-715*560RO	12000002	2	0	0	0	0	560	0	0,68		<input type="text"/>
SEPARADOR-715*501ROBLE	SEG-715*501RO	12000006	1	0	0	0	0	501	0	0,34		<input type="text"/>
SOBRE-1200*600ROBLE	SOG-1200*600RO	12000001	1	0	0	0	0	600	0	0,34		<input type="text"/>
SOPORTE-860*40ROBLE	SOG-860*40RO	12000008	1	0	0	0	0	40	0	0,34		<input type="text"/>
TRASERA-1082*400ROBLE	TRG-1082*400RO	12000003	1	0	0	0	0	400	0	0,34		<input type="text"/>



ORDENES DE TRABAJO: (ESTANDAR)

Lanzamiento nº: 1200001

F.P. SORIA

17/05/2012

ejemplo mesa

Artículo	Código	Nº OF	Cantidad	Dimensiones Brutas			Dimensiones Netas			Tpo (min)	Observaciones	Reales Cant.
				Largo	Ancho	Alto	Largo	Ancho	Alto			
ZOCALO-200*100ROBLE	ZOG-200*100RO	12000005	2	0	0	0	0	100	0	0,68		
Total:			10							3,4		



CIFP PICOFRENTES C.I.F. G46261590
 CALLE GERVASIO MANRIQUE DE LARA 2
 42004 SORIA - SORIA (ESPAÑA)
 Telf. 975 239443 - Fax. 96 136 61 71
 madera@picofrentes.org

PEDIDO	12000001-0
Entrega Prevista:	31/05/2012
Fecha:	17/05/2012

Página 1 de 1

MERCANCIA ENTREGADA EN: JOSEMI CALLE MAYOR 12 42175 BUITRAGO - SORIA (ESPAÑA) Tel: 975847547 Fax: 975485845	CLIENTE: JOSEMI S.L. CALLE MAYOR 12 42175 BUITRAGO - SORIA (ESPAÑA) C.I.F.: G42172402	000002
TRANSPORTISTA: Masorribas		REPRESENTANTE: DIRECTO

CODIGO ARTICULO	CANTIDAD	DESCRIPCION ARTICULO	PRECIO	IMPORTE
ME-GDP	1	MESA GDP	150,00000	150,00

TOTAL BRUTO	B. IMPONIBLE
150,00	150,00
I.V.A.	TOTAL A PAGAR
16	24,00
	174,00

OBSERVACIONES:	NUM. DE BULTOS: 1	VOLUMEN: 0,00 m3
	Embalaje: ESTANDAR	PESO: 0,000 Kg.
	TERMINOS DE ENTREGA: PORTES PAGADOS	
FORMA DE PAGO: CONTADO		



CIFP PICOFRENTES C.I.F. G46261590
CALLE GERVASIO MANRIQUE DE LARA 2
42004 SORIA - SORIA (ESPAÑA)
Telf. 975 239443 - Fax. 96 136 61 71
madera@picofrentes.org

ALBARÁN	12000001-0
Fecha:	17/05/2012

MERCANCIA ENTREGADA EN: JOSEMI CALLE MAYOR 12 42175 BUITRAGO - SORIA (ESPAÑA) Tel: 975847547 Fax: 975485845	CLIENTE: JOSEMI S.L. CALLE MAYOR 12 42175 BUITRAGO - SORIA (ESPAÑA) C.I.F.: G42172402	000002
TRANSPORTISTA: Masorribas	REPRESENTANTE: DIRECTO	

CODIGO ARTICULO	CANTIDAD	DESCRIPCION ARTICULO
ME-GDP	1	Pedido: 12000001-0 de fecha: 17/05/2012 MESA GDP

OBSERVACIONES: PORTES PAGADOS	NUM. DE BULTOS: 1	Volumen: 0,00 m3
	Embalaje: ESTANDAR	Peso: 0,000 Kg.
	FIRMA TRANSPORTISTA:	CONFIRMO GENERO RECIBIDO FIRMA Y SELLO:



PACKING LIST ALBARÁN Enviado por:

CIFP PICOFRENTES
CALLE GERVASIO MANRIQUE DE LARA 2

42004 SORIA
SORIA - ESPAÑA

G46261590

Masorribas
AVENIDA Maestrat s/n

46131 Bonrepos i miranbell
VALENCIA - ESPAÑA

Consignatario: JOSEMI S.L.

Albarán: 12000001 - 0

Bulto	Descripción	Peso	Largo x Ancho x Alto	Cantidad U.M.
1 de 1	MESA-750*600*1200ROBLE	0,000 Kg	0,00 cm x 0,00 cm x 0,00 cm	1,00 u

Observaciones: Elementos pendientes asignados automaticamente a bulto pedido.

JOSEMI S.L.

Destino: CALLE MAYOR 12
Destination: 42175 BUITRAGO
SORIA
ESPAÑA

Ref. Cliente:
Portes: PORTES PAGADOS
F. Pedido: 17/05/2012
Agencia: Masorribas

(delivery note) **ALBARAN / BULTO N^o** (Package nr.)
12000001-0 1

N^o PEDIDO / ORDER NR.:

12000001-0

1x MESA-750*600*1200ROBLE

Color / Finishing: ROBLE

Instrucciones de montaje dentro de la caja de herrajes
Assembly instructions inside fittings box



Tfno.: 975 239443 Fax: 96 136 61 71 email: madera@picofrentes.org



CIFP PICOFRENTES C.I.F. G46261590
 CALLE GERVASIO MANRIQUE DE LARA 2
 42004 SORIA - SORIA (ESPAÑA)
 Telf. 975 239443 - Fax. 96 136 61 71
 maderas@picofrentes.org

FACTURA	00000001-0
Fecha:	17/05/2012

Copia para Oficina

Página 1 de 1

CLIENTE: 000002 JOSEMI S.L. CALLE MAYOR 12 42175 BUITRAGO - SORIA (ESPAÑA) C.I.F.: G42172402	DIRECCIÓN DE ENVÍO: JOSEMI CALLE MAYOR 12 42175 BUITRAGO - SORIA (ESPAÑA) Tel: 975847547 Fax: 975485845
REPRESENTANTE: DIRECTO	

CODIGO ARTICULO	CANTIDAD	DESCRIPCION ARTICULO	PRECIO	IMPORTE
ME-GDP	1	Albarán: 12000001-0 de fecha: 17/05/2012 N/Pedido: 12000001-0 MESA GDP	150,00000	150,00

TOTAL BRUTO	B. IMPONIBLE
150,00	150,00
I.V.A.	TOTAL A PAGAR
16 24,00	174,00

OBSERVACIONES:
 VOLUMEN: 0,00 M3

NUM. DE BULTOS: 1
 PESO: 0,000 Kg.

Embalaje: ESTANDAR

FORMA DE PAGO: CONTADO
 CUENTA BANCARIA:

EFFECTOS	VENCIMIENTOS	IMPORTES	EFFECTOS	VENCIMIENTOS	IMPORTES	EFFECTOS	VENCIMIENTOS	IMPORTES
00000001/1	17/05/2012	174,00						



CIFP PICOFRENTES C.I.F. G46261590
 CALLE GERVASIO MANRIQUE DE LARA 2
 42004 SORIA - SORIA (ESPAÑA)
 Telf. 975 239443 - Fax. 96 136 61 71
 madera@picofrentes.org

FACTURA	00000001-0
Fecha:	17/05/2012

Copia para el Cliente

Página 1 de 1

CLIENTE: JOSEMI S.L. CALLE MAYOR 12 42175 BUITRAGO - SORIA (ESPAÑA) C.I.F.: G42172402	000002	DIRECCIÓN DE ENVÍO: JOSEMI CALLE MAYOR 12 42175 BUITRAGO - SORIA (ESPAÑA) Tel: 975847547 Fax: 975485845
		REPRESENTANTE: DIRECTO

CODIGO ARTICULO	CANTIDAD	DESCRIPCION ARTICULO	PRECIO	IMPORTE
ME-GDP	1	Albarán: 12000001-0 de fecha: 17/05/2012 N/Pedido: 12000001-0 MESA GDP	150,00000	150,00

TOTAL BRUTO	150,00	B. IMPONIBLE	150,00
I.V.A.		TOTAL A PAGAR	
16	24,00		174,00

OBSERVACIONES:
 VOLUMEN: 0,00 M3

NUM. DE BULTOS: 1
 PESO: 0,000 Kg.

Embalaje: ESTANDAR

FORMA DE PAGO: CONTADO
CUENTA BANCARIA:

EFFECTOS	VENCIMIENTOS	IMPORTES	EFFECTOS	VENCIMIENTOS	IMPORTES	EFFECTOS	VENCIMIENTOS	IMPORTES
00000001/1	17/05/2012	174,00						